

Specification:

Population range: 6 persons

Measures: 243 x 122 x 220 cm (l,w,h) (standard variant, complete height with aeration scoop)

Sludge treatment: stabilizing, volumereduction

Max. organic loading: 360g BOD/Day

Max. average daily flow: 900 L

Max. blower power consumption: 0,08 kw

Weight (total/plug&play): ~180 kg

Total capacity: 3.500 L

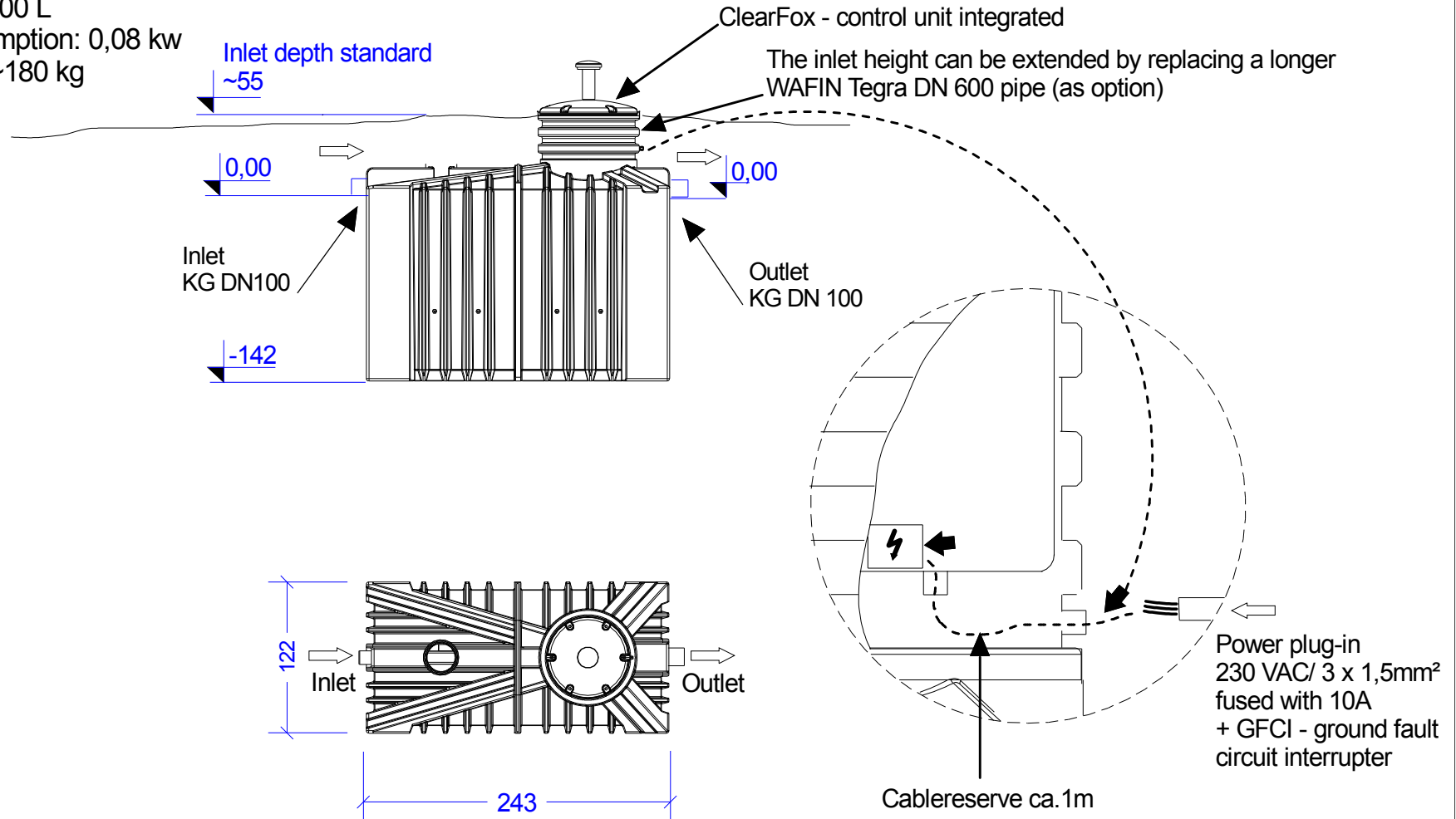

all measures in cm

ClearFox- QuickONE +
small wwntp 6 p.e.
Single chamber SBR system
according EN 12566-3